

Height Adjustable Sit-Stand Solutions



The benefits of standing

The human body has evolved for movement so it follows that the freedom to alternate between sitting and standing at work can help maintain both physical and mental health

Research shows that the freedom to alternate between sitting and standing boosts productivity and improves well-being by allowing the office worker to choose the best posture for the task

Electric Height-adjustable Desks



The Risks of Sedentary Work

The office is the engine of the 21st century. The typical office worker can spend a large part of their working day seated and research shows that this can pose serious health risks. Many now consider sedentary work to be the new smoking. Standing all day poses risks of its own, therefore alternating between sitting and standing will help reduce risk, promoting good health and wellbeing at work.

EDF0 Electric Height Adjustable Desk Features

Advanced Control



- Responsive and easy to use which encourages alternating between sitting and standing
- Simple single handed control for fast, accurate adjustments
- 3 Memory presets & timer function for convenience

3 Column Design

- Upto 33% quicker than 2 column models
- Quite soft start/stop motors built into the table leg with energy efficient low draw transformers
- 3 Stage steel frame, is quicker, quieter and more stable



Choice of desktops



Cable Management

Electric Height-adjustable Desks

(frame only)



Unique Motor
Powerful and silent



Power Input
100V-240V



Max. Speed
38 mm/s



Motion Noise
<50dB



Overload Protection



Operation Temperature
-5°C~+40°C



Thermal Protection



IP Grade
IP20



Advanced Controller
3 programmable memory with LED display



Double Motor



Sit/Stand Time Reminder



100 kg Load

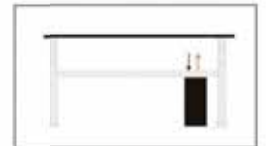

Collision Avoidance System

EDF02D

Dual-motor Height Adjustable Desk Frame

Height range: 63-125cm
Max load: 100kg/220lbs
Net weight: 35kg

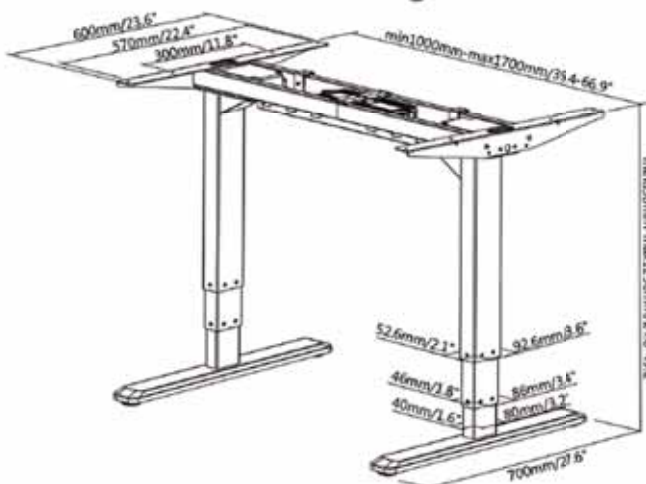

EDF04Q

Quad-motor Height Adjustable Desk Frame

Height range: 63-125cm
Max load: 100kg/220lbs
Net weight: 50kg

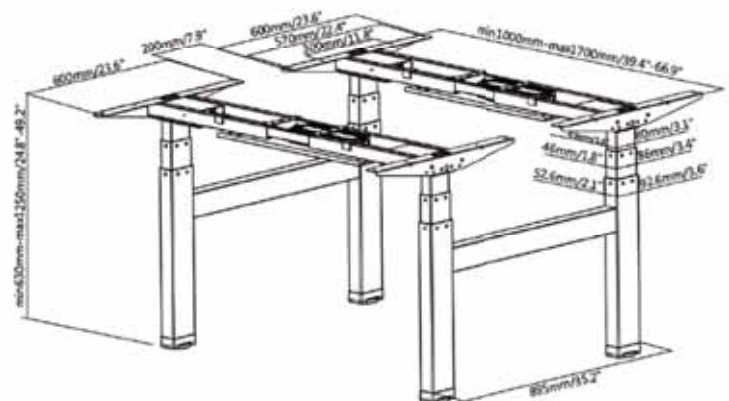

EDF01SN



Single-motor Height Adjustable Desk (normal columns)

Height range: 73-123cm
Max load: 80kg / 176lbs
Net weight: 24kg
Package size: 113x27x22cm

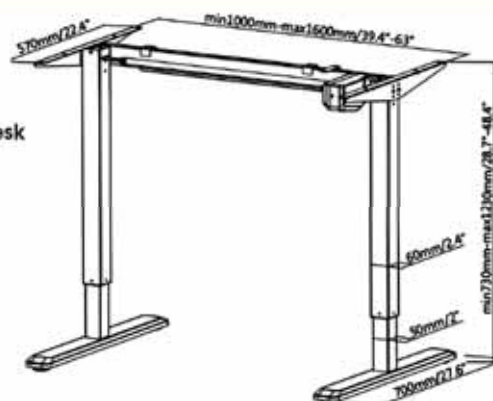

80 kg Load



Simple Controller



Single Motor

Pneumatic Height Adjustable Desks & Tables

We highly recommend our range of electric height adjustable desks, however there can be times when finding a suitable power supply can be a problem. Our pneumatic height adjustable desks and tables let you alternate between sitting and standing without electricity. The pneumatic gas lift gives a helping hand to easily find the right height to complete tasks in comfort.



GDFO02MW - Pneumatic Height Adjustable Desk

- Be more productive in a comfortable workspace with a pneumatic height adjustable desk.
- Strong steel frame can support upto 100kg including the desktop without electricity
- Ideal for light duty home offices upto heavy duty tasks with multiple monitors and devices.

GDFO02MW - Features

- Smooth and effortless pneumatic gas spring provides 15kg of uplift
- Height adjustment range of 72cm-114cm
- Compatible with worktops 130cm-160cm wide & 60-80cm deep

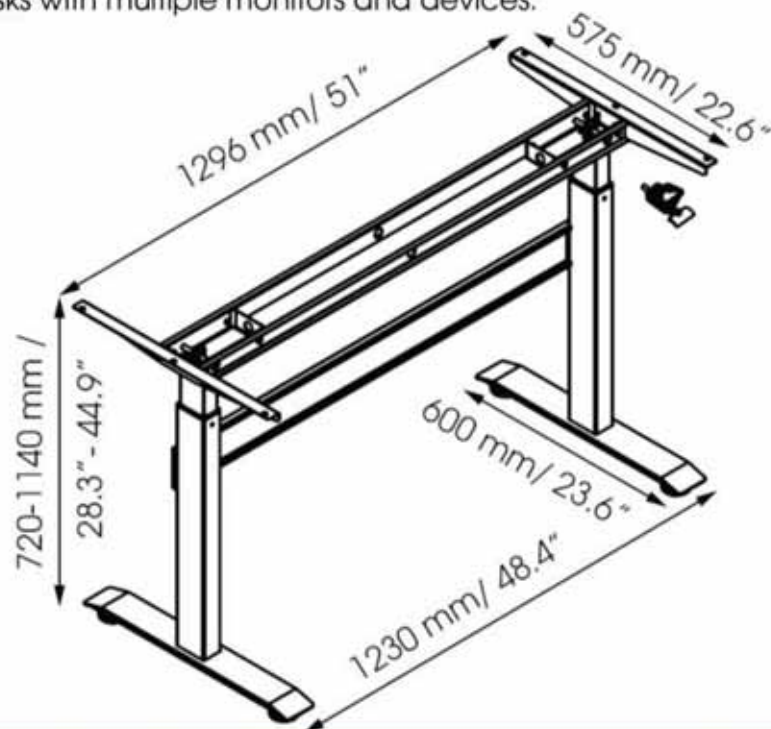

WST01 - Pneumatic Height Adjustable Lectern

- Height adjustment range 79-119cm
- Strong steel frame can support a max lod of 80kg
- Pneumatic gas lift gives a helping hand with 8kg uplift
- Large 79x52cm work surface
- 90 degree tilt for comfort
- Folds flat with sturdy castors for easy transport and storage
- 2 Level adjustment pads for quick set up

Height Adjustable Desk Accessories

CPB-Series CPU Holder

- 360 Degree swivel for easy access to cables and ports
- Can be mounted to either to wall or under the desk for protection against accidents, spills and contaminants.
- Adjustable from 88mm to 203mm to fit almost any ATX computer case.
- Manufactured from high quality powder coated steel with 5 year warranty.



DP-Series Desktop Power Modules

- Desktop, inset flip up and grommet pop up versions available
- Convenient access to power sockets, USB fast charging ports & RJ45 network ports.
- Includes 2 meter kettle lead with 13A UK plug with 5 year warranty

CT-Series Cable Trays

- Simple, sturdy under desk cable management tool, can be mounted either under the desk or to a wall.
- Cable covers prevent cables and wires spilling out
- Heavy duty steel wire and fire resistant plastic mountings can support upto 5kg.
- Additional mounting tools available for heavier loads.
- Easily linked together to make custom lengths and wide choice of lengths available.

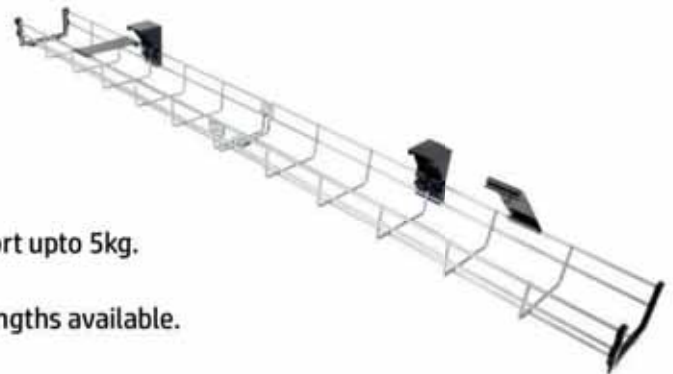

CS-Series Cable Spine

- Attractive, practical solution to keep cables neat and tidy
- Designed to follow the movement of any height adjustable desk
- Total height of 130cm and manufactured from strong ABS snap interlink blocks with 7" diameter steel base plate and a 5 year warranty.

Sit-Stand Desk Converters

Get the benefits of standing without changing your desk with our range of sit stand desk converters. Relieve the impact of bad posture and be free from the restrictions of the modern office without electricity. Features easy pneumatic lift and dedicated keyboard space.



GSS03 - Sit Stand Desk Converter

- Pneumatic gas spring action changes height from sitting to standing in one smooth motion
- Alternate between sitting and standing using your existing desk
- Integrated keyboard & mouse tray with phone/tablet slot
- Strong steel construction with weighted base can support upto max 13.6kg

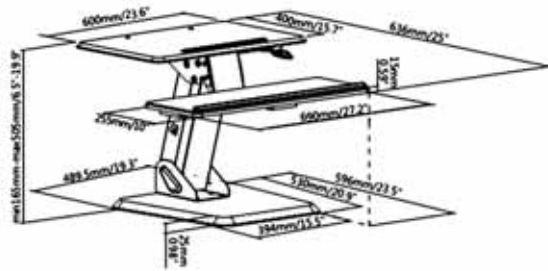

GSS061 - Sit Stand Desk Converter

- Height Adjustment 11-51cm
- Pneumatic gas spring action changes height from sitting to standing in one smooth motion
- Integrated keyboard & mouse tray with phone/tablet slot
- Heavy duty steel construction can be fitted with a wide range of monitor arms
- Alternate between sitting and standing using your existing desk

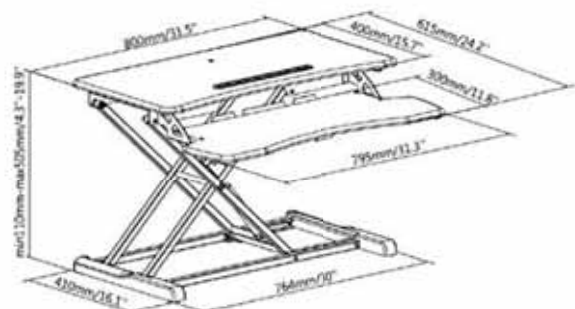

Pneumatic Height Adjustable Tables

GBT05 - Assisted Lift Over Bed/Chair Table

- Attractive and strong height adjustable over bed/chair table with large surface
- With pneumatic lift the table rises smoothly without the need for unlocking



GBT05 - Features

- Height adjustment range of 74-114cm
- Pneumatic gas spring provides smooth uplift of 8kg
- Heavy duty steel frame supports a max load of 80kg
- Choice of pads or castors (pads included as default)
- Large 69 x 48cm tabletop

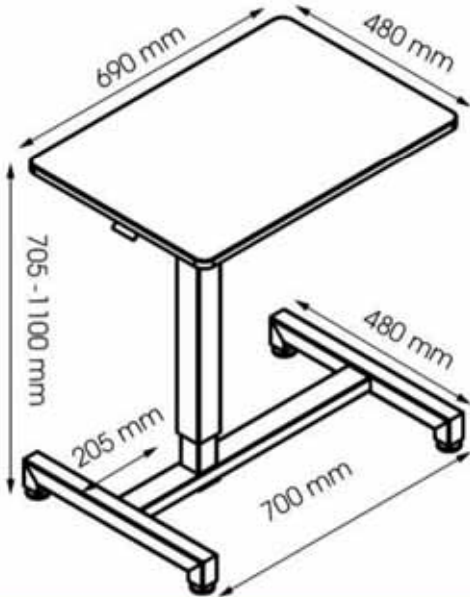

WST50AW - Height Adjustable Meeting/Bistro Table

- Versatile height adjustable meeting desk, ideal for offices, schools waiting rooms and lunch areas
- Easy to use pneumatic paddle quickly and smoothly adjusts the table from sitting to standing height



WST50AW - Features

- Height adjustment range 70-160cm
- Pneumatic gas springs giving 6kg uplift for effortless height adjustment
- Heavy duty steel frame and base supporting a max load of 60kg

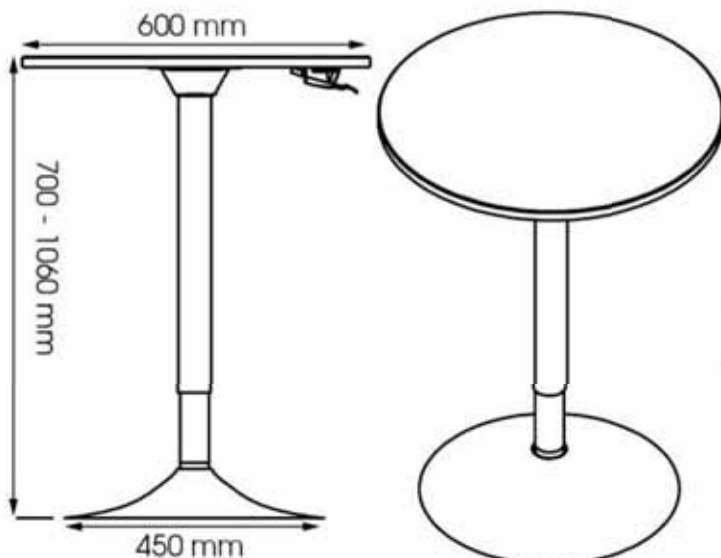

Universal Mini PC Mount Adapter Thin Client Mount Adapter



MPA01 Mini PC Mount Adapter



- Mount your mini PC/ NUC to a monitor or monitor arm / stand
- Universal, for all mini PCs with threaded mounting holes
- Unique shape providing convenient access to mini PC

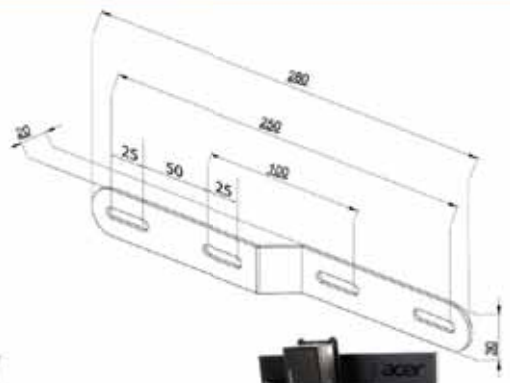

Universal Mount
for both VESA & Non-vesa mini PCs



Mounting Option #1



Mounting Option #2, #3

TCM01 Thin Client Mount Adapter

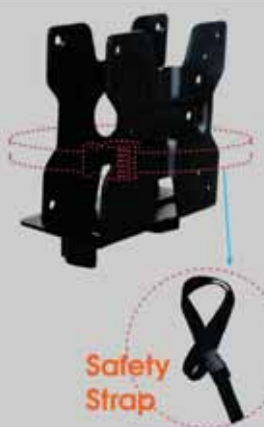

- Mount thin client / mini PC in 5 different ways
- Strap for additional security
- Heavy duty, support up to 5 kg (11 lbs)
- Includes pole clamp for $\varnothing 35 - \varnothing 42$ poles
- VESA 100x100 and 75x75

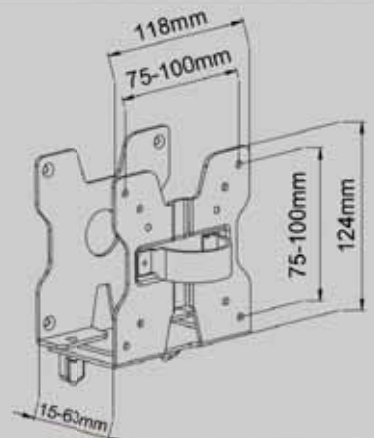

Mounting Option #1
to the back of a LCD



Mounting Option #2, #3
between a LCD & Arm



Mounting Option #4
to a $\varnothing 35 - \varnothing 42$ pole



Mounting Option #5
under a desk / table